

NEW 52T TRACTOR FROM ASHOK LEYLAND



- First OEM with 52T ARAI
- 4X2 tractor with 6X4 efficiency
- Payloads close to 55T tractor
- Lowest TCO
- 60% more profits than 55T
- High torque 'A' series engine
- i-Gen6 technology and modular platform

Ashok Leyland creates a new GCW node in tractor: 5225 TT

Sr. no.	Description	Axle load (tons)
1	Single axle with 2 tyres	7.0
2	Single axle with 4 tyres	*11.5
3	Tandem (two) axles - where the distance between two axles is < 1.8m	21.0
4	Tridem (three) axles - where the distance between three axles is < 3m	27.0

*Additional 1T allowed if fitted with air suspension

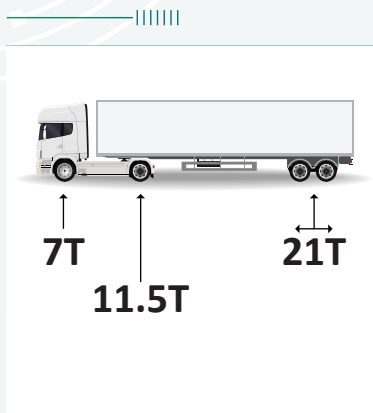

40T - 4X2T + 2 axle TT
39.5 GCW

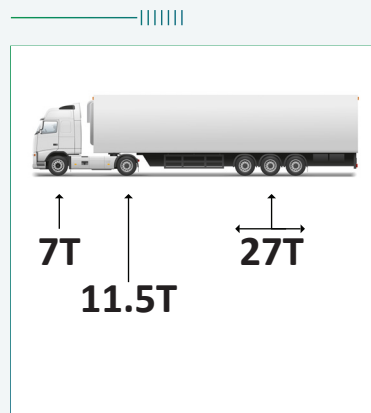

46T - 4X2T + 3 axle TT
45.5 GCW

There is a wide product gap between 46T and 55T tractors. To bridge this gap, we combined a single axle with 4 tyres and tandem axle. The trailer load capacity increased from 27T to 33.5T by fitting air suspended lift axle for the new 5225 TT

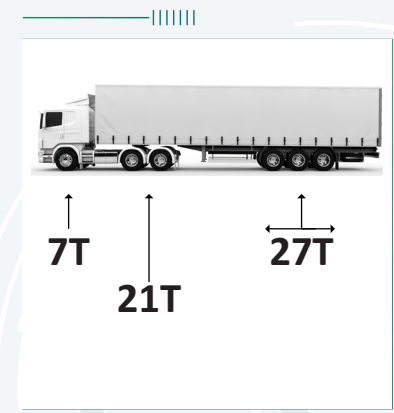

55T - 6X4T + 3 axle TT
55T GCW

The new trailer configuration - 5225 TT

Ashok Leyland, always first in addressing customer needs, introduces the new 52T tractor series in 4X2 BS-VI configuration

- Trailer modified 52T tractor with 3 axle semi trailer (retractable lift axle - air suspension and tandem axles)
- 51T passing GCW possible if non-air suspended axle used

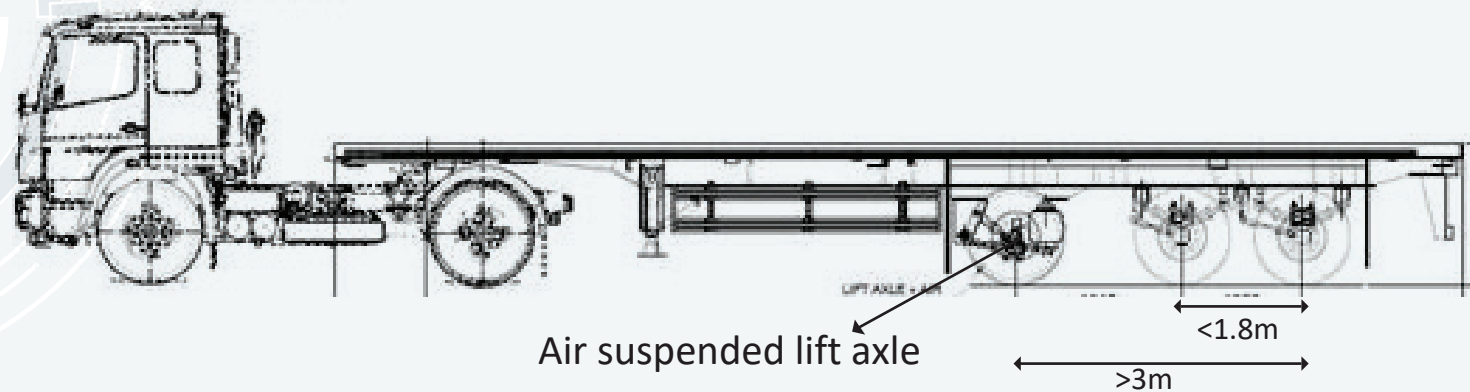

- Current 4X2 tractor 46T TT with 3 axle semi trailer (non retractable axle - mechanical suspension and tandem axles)

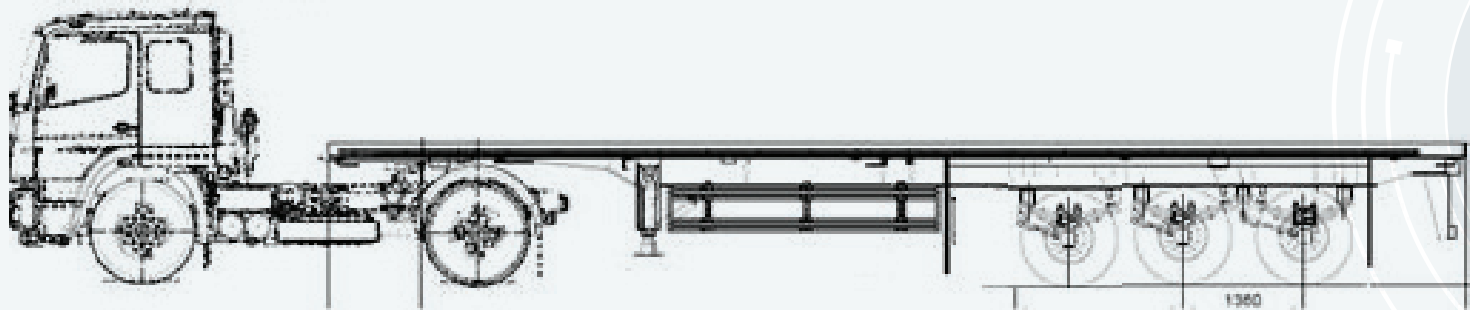

16% lower TCO and 60% higher profits* with 52T tractor

Application: RLRL - cement gypsum	BS-IV	BS-VI			5225 - 
Model	U 5523	5525 AN	5225 AN	4620 AU	
KM per trip	1100	1100	1100	1100	
Onward load (tons)	42	42	39.5	34	
Return load (tons)	42	42	39.5	34	>5.5 T payload than 46 T / 2.5 T < 55T
Earning per trip	65940	65940	62105	53380	785/- per ton
Trips per month	7	7.5	7.5	7	10% trip extra due to captain cab
Diesel cost per month (INR)	215600	220000	179701	167721	
DEF cost per month (INR)	0	5657	4621	4313	
Tyre cost per month (INR)	38500	33811	21214	19800	
No. of tyres	22	22	18	18	
Total variable cost per month (INR)	298585	302432	248500	234189	5225 gives very low variable cost
Total cost of ownership per month	410460	428162	370104	343876	
Cost per km	53.31	51.90	44.86	44.66	
Relative cost per km	100	97	84	84	5225 gives best TCO - 16% lower than 55T
Operating revenue per month	461580	494550	465113	373660	
Profit per month	78620	98780	125842	56450	
Profit per km	10.21	11.97	15.25	7.33	
Relative profit per km	100	126	160	72	5225 gives the best profit - 60% more profit than 55T

(*Compared to 55T of BS-IV)

Low on cost, high on revenues, superb on profits

Variable cost per month (lakh in ₹)

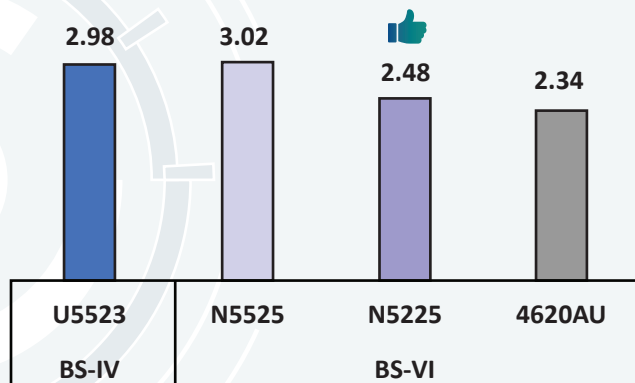

- Low monthly variable cost than 55 T BS-IV and BS-VI

Cost per km (₹)

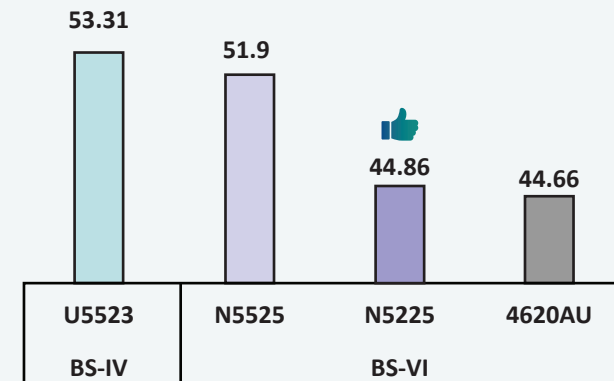

- Very low operating cost per km

Profit per km (₹)

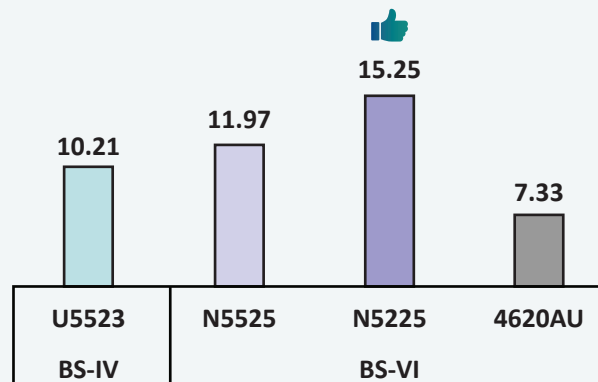

- Highest profit per km



ASHOK LEYLAND

Aapki Jeet. Hamari Jeet.

e-DIAGNOSTICS

LEYKART

RECON

LEYPARTS®

VALUEPARTS
Right-fit for Ashok Leyland vehicles

AMC

EXTENDED WARRANTY

QUICK RESPONSE



SERVICEMANDI

HELPLINE

1800-266-3340

AUTHORISED DEALER:

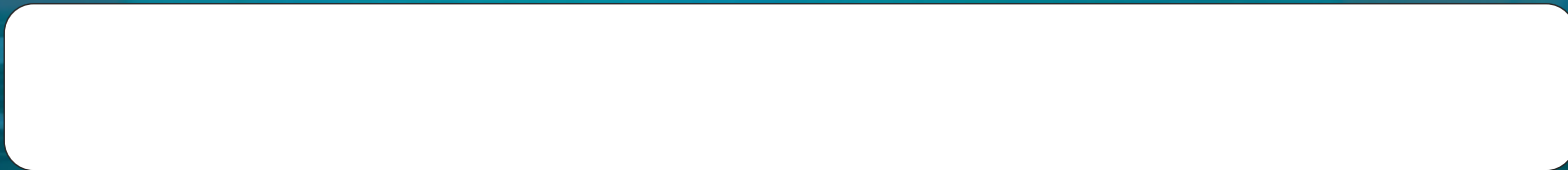

**Registered Office - Ashok Leyland Limited, No. 1, Sardar Patel Road, Guindy, Chennai - 600032,
Tel. - 91 44 2220 6000 E-mail - reachus@ashokleyland.com | Website - www.ashokleyland.com**