



**BUILD YOUR
OWN TRUCK**

5425 SERIES



- First OEM to get ARAI certification up to 54 tons
- Payloads exceeding 55T 6X4 tractor
- Power dense and high torque engine
- i-Gen6 technology and modular platform
- Lowest TCO and highest profit potential in trucking

Wide range of 4X2 tractors for any application

Now select your choice of single crown (4x2) tractors from 54/ 52/ 51 tons to replace your double crown 55T tractors

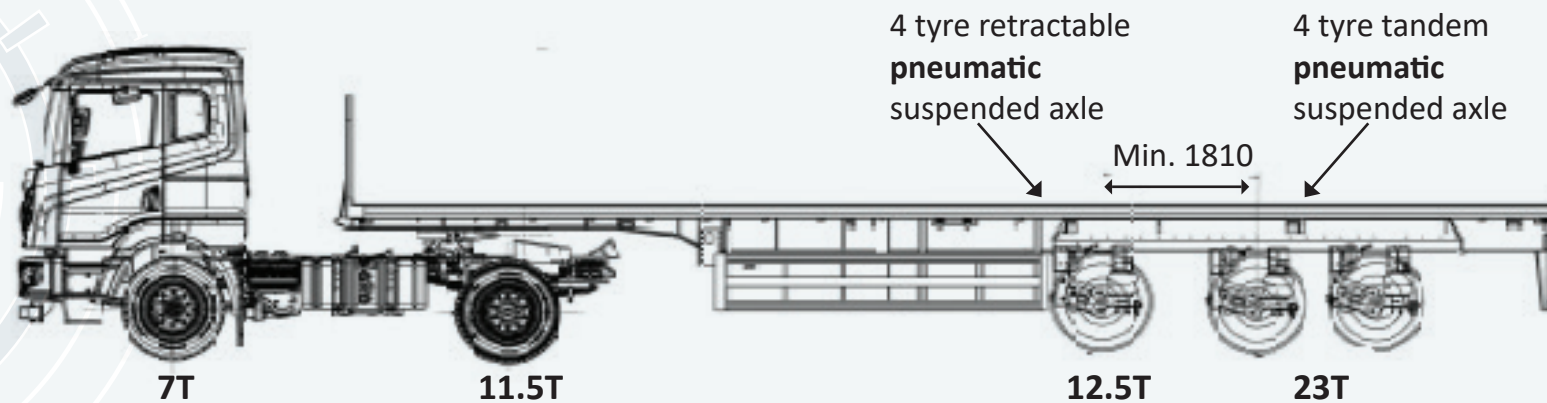

5425 TT

Major applications: Steel/ Container/ Market load

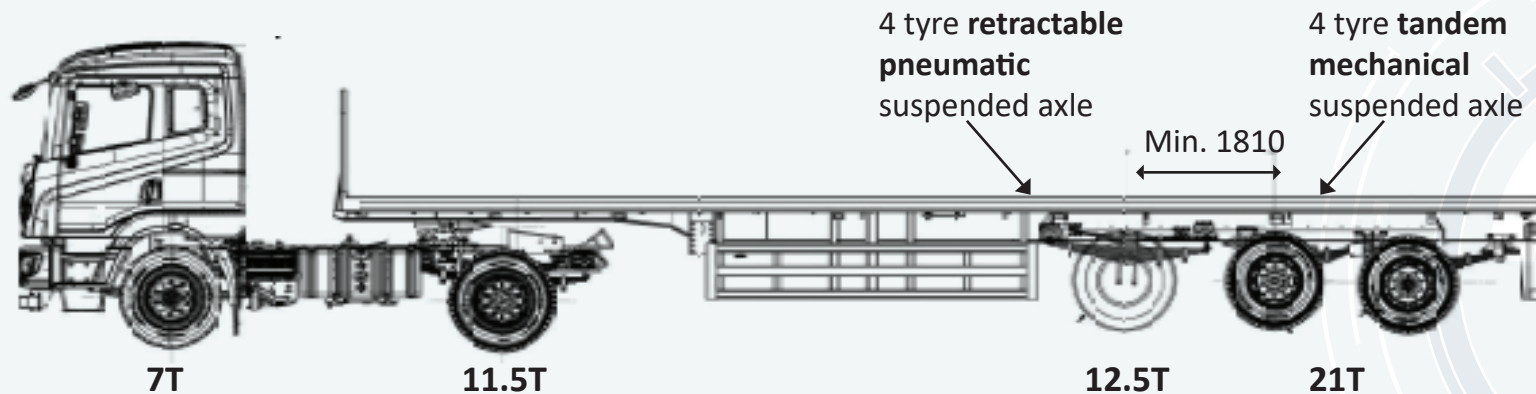

5225 TT

Major applications: Cement/ Market load

Wide range of 4X2 tractors for any application

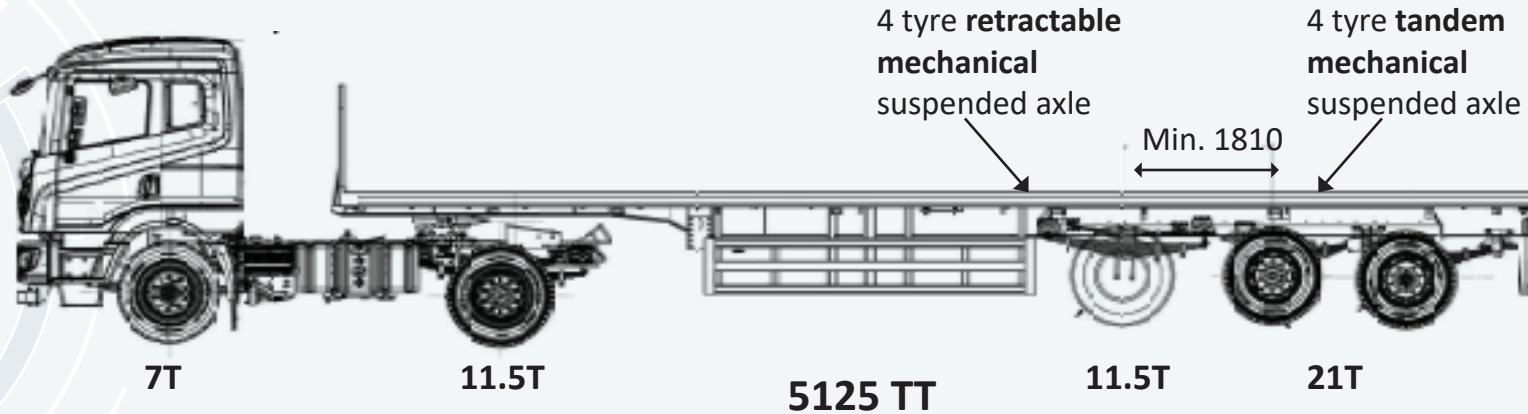

Major applications: Cement/ Market load/ Blue metal

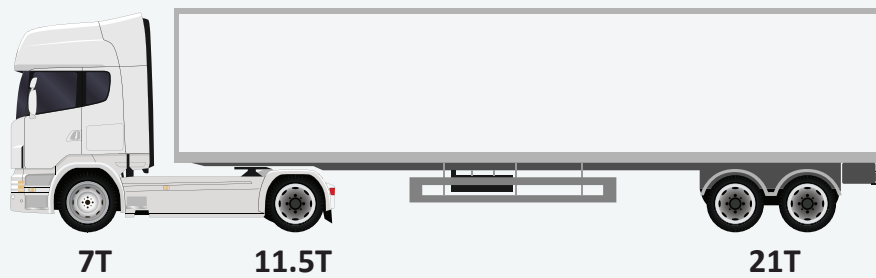

4020 TT

Major applications: Container/ Market load/ E-commerce



4620 TT

Major applications: Container/ Cement/ Coal/ Tanker

Model, payload and TCO matrix: Earn highest profits in 5425

GCW	ULW # (ton)	Payload (ton)	Earning/ month (Lakh)	Fluid cost/ month (Lakh)	Tyre cost/ month (Lakh)	TCO/ month* (Lakh)	Cost/ km (₹)	Profit/ month (Lakh)	Profit/ Km (₹)
5425	14.50	39.5	4.97	1.91	0.21	3.81	46.28	1.15	14.04
5225	14.40	37.6	4.73	1.91	0.21	3.77	45.73	0.96	11.68
5125	14.35	36.6	4.61	1.91	0.21	3.75	45.45	0.86	10.43
5525	15.90	39.1	4.93	2.25	0.34	4.28	51.90	0.64	7.83

*Above values as per cement/ gypsum 2 side load application for the purpose of TCO comparison

Theoretical calculation. To be verified after body building

Cost per km (₹)

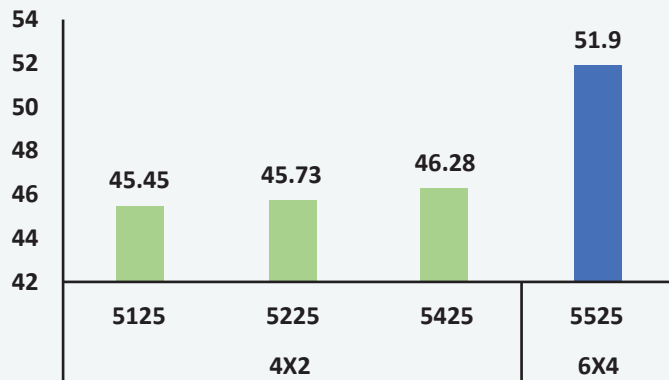

Profit per km (₹)

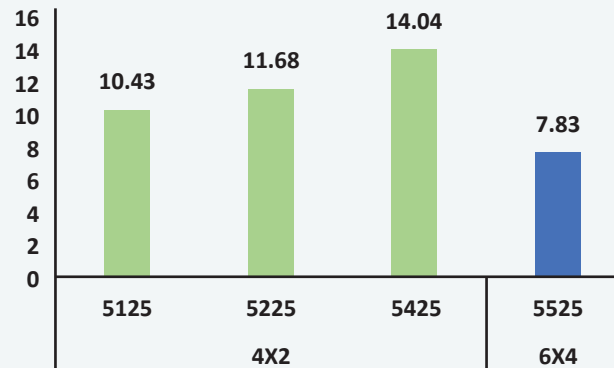

Profit per month (₹ in Lakh)

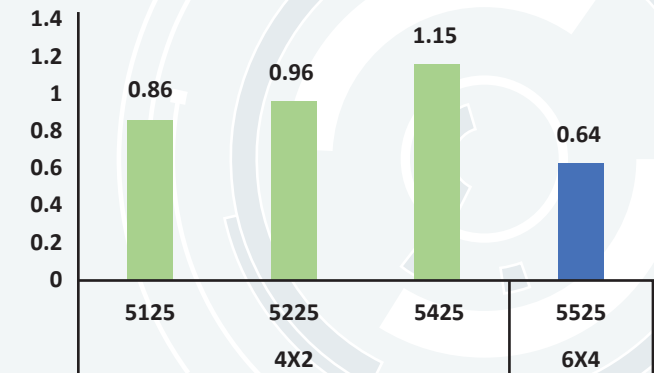

4X2 tractors: the right choice!

GCW	Ref. application	ULW # (ton)	Payload (ton)	Earning/month (Lakh)	Fluid cost/month (Lakh)	Tyre cost/month (Lakh)	TCO/month (Lakh)	Cost/km (₹)	Profit/month (Lakh)	Profit/km (₹)	Incremental profit/month over 5525 (₹)	
5425	Cement (2 side load)	5425	14.50	39.5	4.97	1.91	0.21	3.81	46.28	1.15	14.04	50000
		5525	15.90	39.1	4.92	2.25	0.34	4.28	51.9	0.65	7.83	
5225	Market load (2 side load)	5225	14.40	37.6	4.59	1.89	0.22	3.57	41.97	1.01	11.96	32000
		5525	15.90	39.1	4.78	2.24	0.35	4.09	48.01	0.69	8.11	
5125	Blue metal (1 side load)	5125	14.35	36.6	5.37	2.83	0.28	4.80	45.04	0.56	5.33	33000
		5525	15.90	39.1	5.74	3.48	0.43	5.50	51.58	0.23	2.23	

Theoretical calculation. To be verified after body building

Unique advantages

- Increased payload in 4X2 tractor configuration: The best for RL/ RL applications
- Earn up to ₹ 50,000 more profits than 6x4 tractors
- Less tyre wear with trailer lift axle (air suspended)
- Better fuel efficiency due to uniform tyre contact (air suspended)
- Improves driver comfort due to minimal vibrations (air suspended)

5425 AN technical specification

SPECIFICATIONS

Engine type	A series BS-VI 5.3L, CRS with i-Gen6 technology
Max. power	250 HP @ 2200 rpm
Max. torque	900 Nm @ 1200- 2000 rpm
Clutch	395 mm diameter- single dry plate, ceramic clutch with air assisted hydraulic booster
Gearbox type	9S1110- 9 speed synchromesh
Rear axle	Fully floating single speed rear axle, RAR: 6.17 :1 Optional : unitized wheel bearings
Front axle	Forged I section- Reverse Elliot type with anti-roll bar Optional: unitized wheel bearings
Suspension	Front: parabolic springs Rear: Semi-elliptic multileaf, helper spring-parabolic
Steering	Hydraulic assisted power steering
Chassis frame	275X75X8 mm- bolted construction
Brakes	Full air dual line brakes with ABS Engine brake and auto exhaust brake
Fuel tank	Cross link polymer Capacity 375 litres
Ad blue tank	48 litres
Max. speed	80 kmph
Electricals	24V- 120Ah (150Ah for AC/HVAC variants)
Tyres	295/ 90R20- 16 PR
Gradeability	22.8%
Cabin	N - premium cabin - A.C. and HVAC (optional)
Vehicle configuration options	Cabin and chassis
Chassis weight (Laden) kgs	FAW- 7000; RAW- 11500 GCW- 54000 (when coupled with suitable 3 axle trailer)

MAJOR DIMENSIONS

Wheelbase (mm)	3400
Overall length (mm)	5950
Turning circle diameter (m)	12.6
Overall width (mm)	2570 (over fenders)
Overall height (mm)	3247

SCHEMATIC LAYOUT

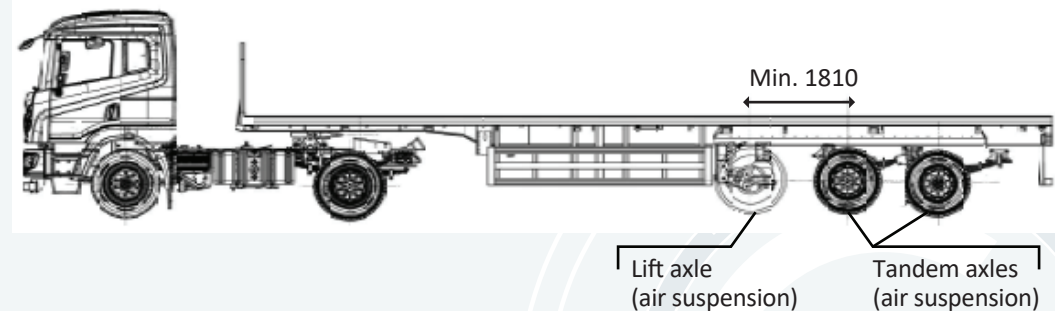

APPLICATIONS



Market load



Container



Steel



Cement



ASHOK LEYLAND

Aapki Jeet. Hamari Jeet.

e-DIAGNOSTICS

LEYKART

RECON

LEYPARTS®

VALUEPARTS
Right-fit for Ashok Leyland vehicles

AMC

EXTENDED WARRANTY

QUICK RESPONSE



SERVICEMANDI

HELPLINE

1800-266-3340

AUTHORISED DEALER:

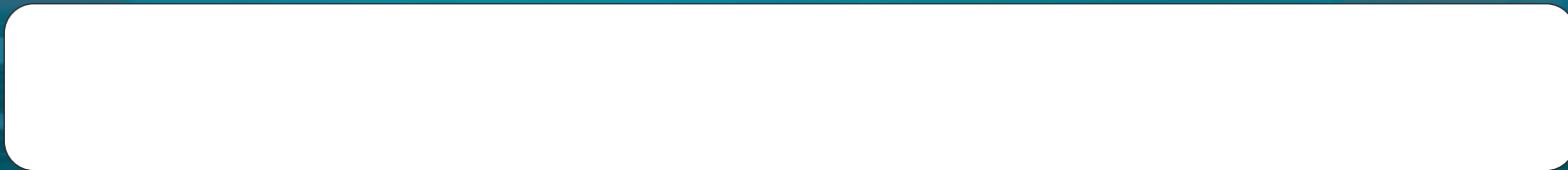

**Registered Office - Ashok Leyland Limited, No. 1, Sardar Patel Road, Guindy, Chennai - 600032,
Tel. - 91 44 2220 6000 E-mail - reachus@ashokleyland.com | Website - www.ashokleyland.com**